

Benefits

- Replace Bipolar with Unipolar Rectifiers
- Essentially No Switching Losses
- Higher Efficiency
- Reduction of Heat Sink Requirements
- Parallel Devices Without Thermal Runaway

$V_{RRM} = 650\text{ V}$
$I_F, T_C < 135^\circ\text{C} = 14.5\text{ A}$
$Q_c = 24\text{ nC}$

General Features

- 650-Volt Schottky Rectifier
- Zero Reverse Recovery Current
- Zero Forward Recovery Voltage
- High-Frequency Operation
- Temperature-Independent Switching Behavior
- Extremely Fast Switching
- Positive Temperature Coefficient on VF

Package TO-220-2

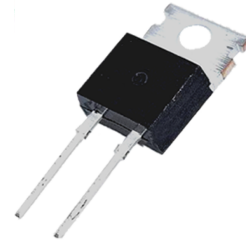

Application

- Switch Mode Power Supplies (SMPS)
- Power Factor Correction
- Motor Drives

Equivalent Circuit



Absolute Maximum Ratings ($T_A=25^\circ\text{C}$ unless otherwise noted)

Parameter	Symbol	Value	Unit
Repetitive Peak Reverse Voltage	V_{RRM}	650	V
Surge Peak Reverse Voltage	V_{RSM}	650	V
DC Blocking Voltage	V_{DC}	650	V
Forward Current(Fig.3)	I_F	$T_C \leq 25^\circ\text{C}$	30
		$T_C \leq 135^\circ\text{C}$	14.5
		$T_C \leq 153^\circ\text{C}$	10
Non-Repetitive Forward Surge Current(Fig.8)	I_{FSM}	$T_C=25^\circ\text{C}, t_p=10\text{ ms, Half Sine Pulse}$	90
		$T_C=110^\circ\text{C}, t_p=10\text{ ms, Half Sine Pulse}$	71
Repetitive Peak Forward Surge Current	I_{FRM}	$T_C=25^\circ\text{C}, t_p=10\text{ ms, Half Sine Pulse}$	46
		$T_C=110^\circ\text{C}, t_p=10\text{ ms, Half Sine Pulse}$	31
Non-Repetitive Peak Forward Current(Fig.8)	$I_{F,max}$	$T_C=25^\circ\text{C}, t_p=10\text{ us, Pulse}$	860
		$T_C=110^\circ\text{C}, t_p=10\text{ us, Pulse}$	680
Power Dissipation(Fig.4)	P_{tot}	$T_C=25^\circ\text{C}$	136.5
		$T_C=110^\circ\text{C}$	59
Operating Junction and Storage Temperature	T_J, T_{stg}	-55 ~+175	$^\circ\text{C}$
TO-220 Mounting Torque		M3 Screw	1
		6-32 Screw	8.8
			Nm lbf-in

Electrical Characteristics

Symbol	Parameter	Condition	Min	Typ	Max	Unit
V_F	Forward Voltage(Fig.1)	$I_F = 10A, T_J = 25^\circ C$	--	1.5	1.8	V
		$I_F = 10A, T_J = 175^\circ C$	--	2.0	2.4	V
I_R	Reverse Current(Fig.2)	$V_R = 650V, T_J = 25^\circ C$	--	12	60	μA
		$V_R = 650V, T_J = 175^\circ C$	--	24	220	μA
Q_C	Total Capacitive Charge(Fig.5)	$V_R = 400V, I_F = 10A$ $di/dt = 500A/\mu s, T_J = 25^\circ C$	--	24	--	nC
C	Total Capacitance(Fig.6)	$V_R = 0V, T_J = 25^\circ C, f = 1MHz$	--	460.5	--	pF
		$V_R = 200V, T_J = 25^\circ C, f = 1MHz$	--	44	--	pF
		$V_R = 400V, T_J = 25^\circ C, f = 1MHz$	--	40	--	pF
$R_{\theta JC}$	Thermal Resistance from Junction to Case (Fig.9)		--	1.1	--	$^\circ C/W$
E_C	Capacitance Stored Energy(Fig.7)	$V_R = 400V$	--	3.6	--	μJ

Typical Performance

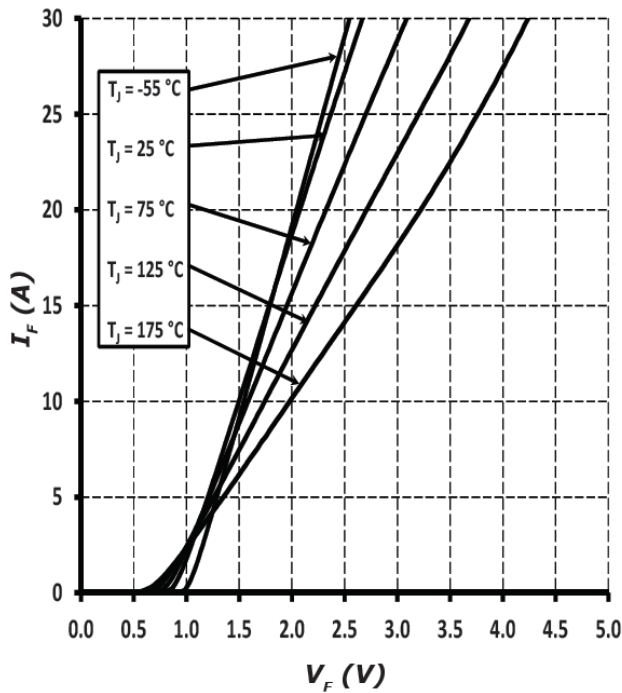

Figure 1. Forward Characteristics

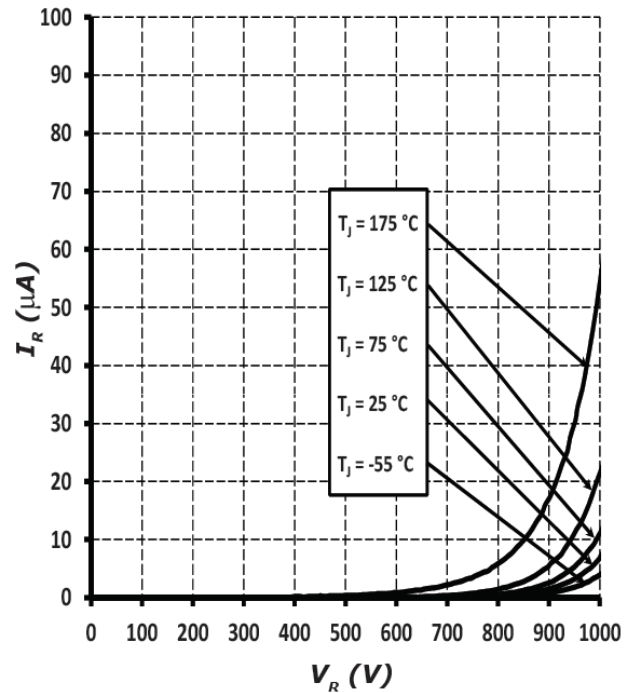

Figure 2. Reverse Characteristics

■ Typical Performance

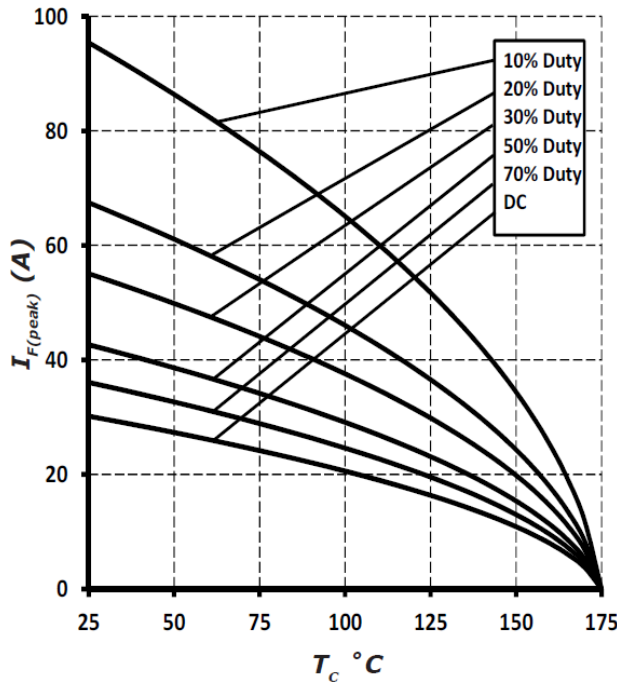

Figure 3. Current Derating

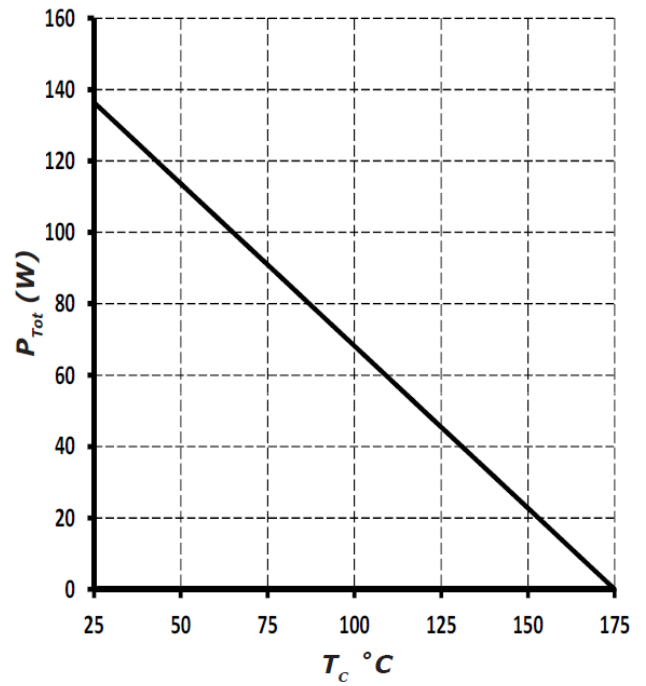

Figure 4. Power Derating

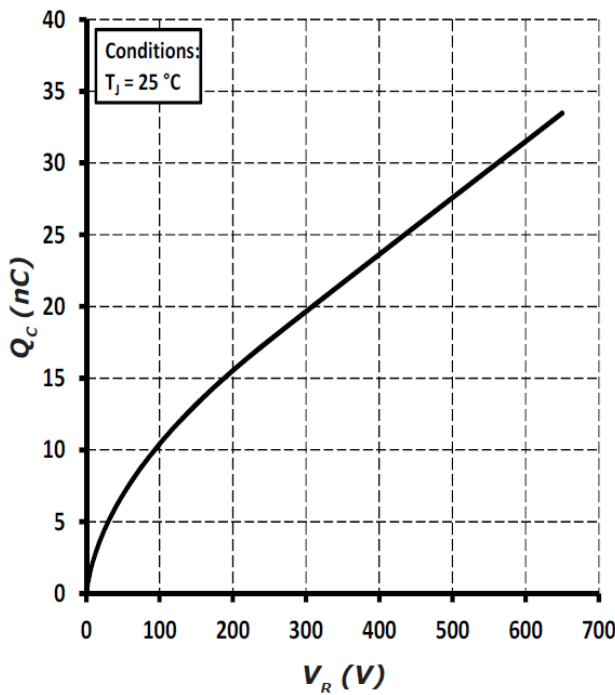

Figure 5. Total Capacitance Charge vs. Reverse Voltage

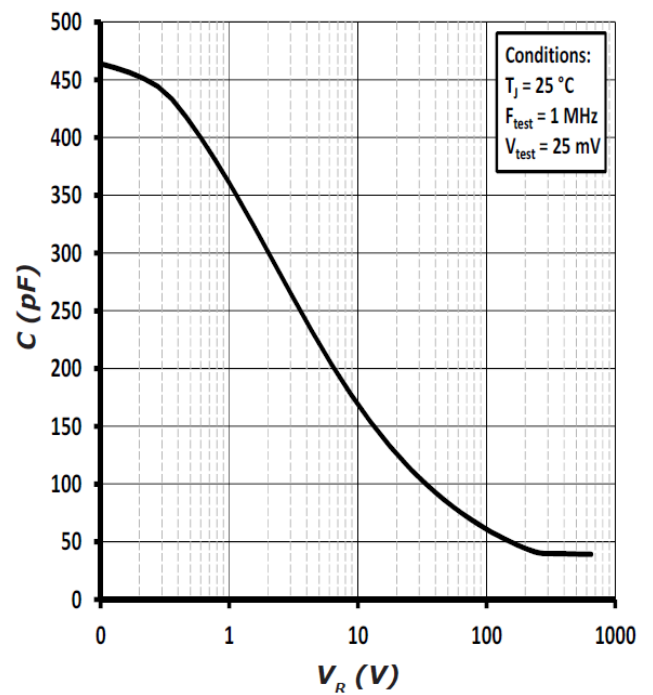

Figure 6. Capacitance vs. Reverse Voltage

■ Typical Performance

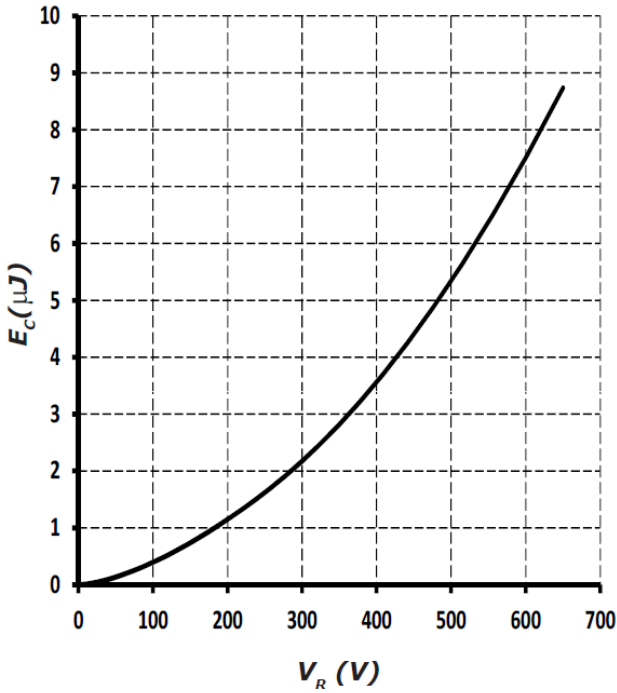

Figure 7. Capacitance Stored Energy

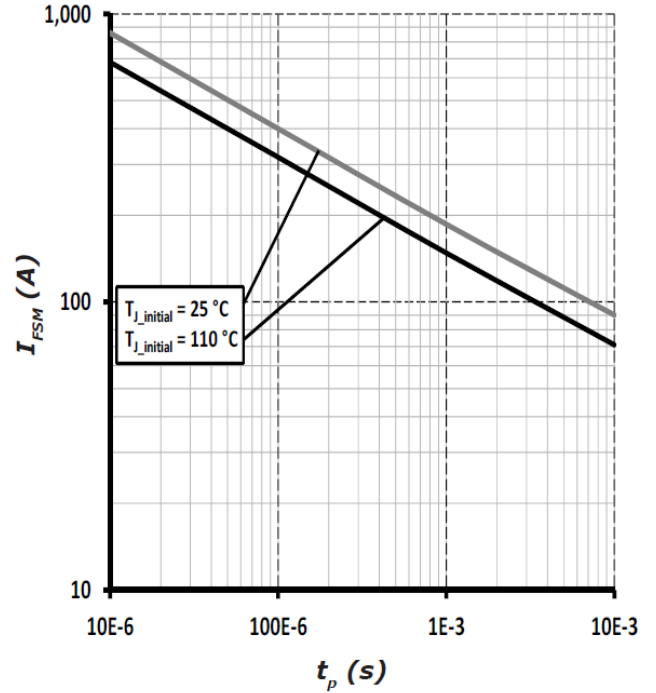

Figure 8. Non-repetitive peak forward surge current versus pulse duration (sinusoidal waveform)

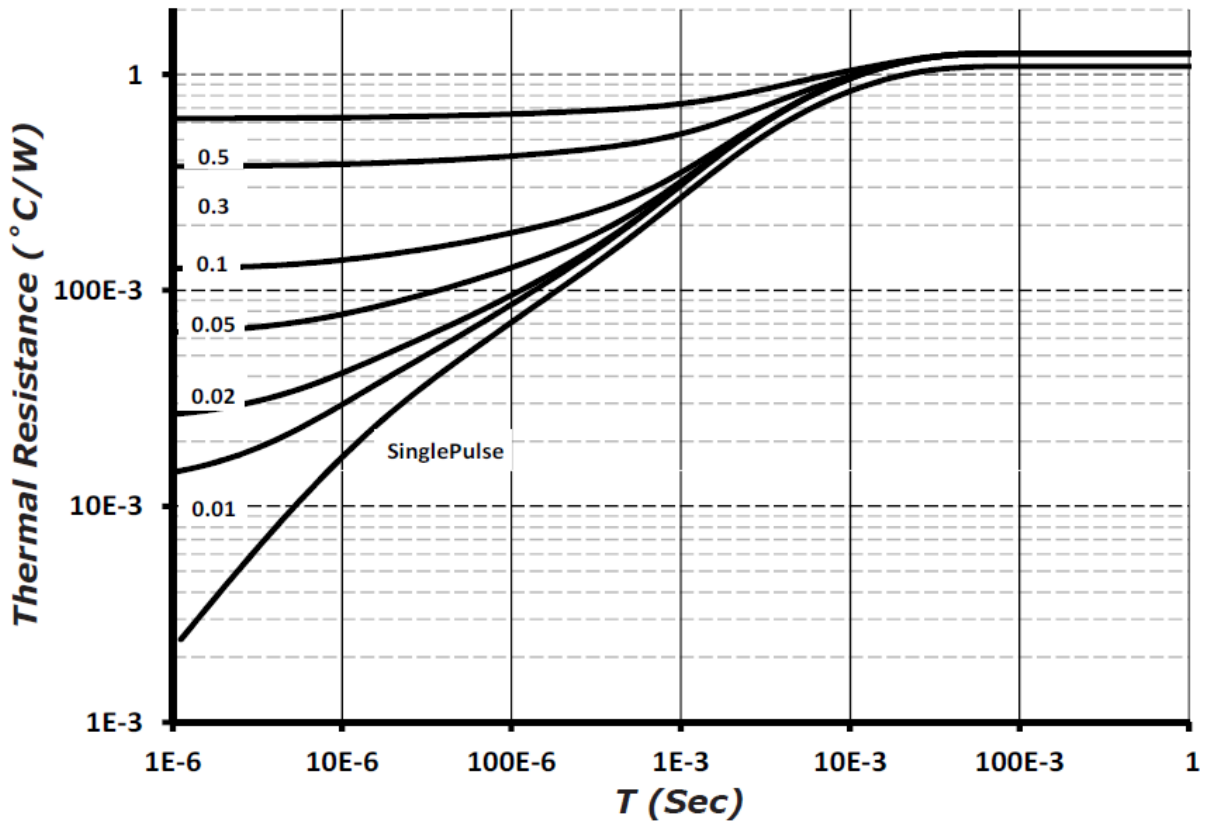
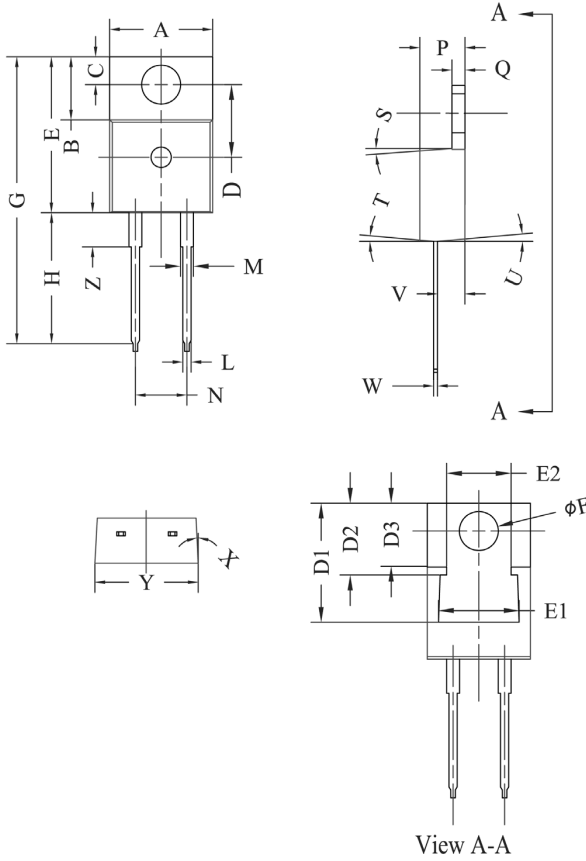

Figure 9. Transient Thermal Impedance

Outline Drawing

TO-220-2 Package Outline Dimensions



POS	Inches		Millimeters	
	Min	Max	Min	Max
A	.381	.410	9.677	10.414
B	.235	.255	5.969	6.477
C	.100	.120	2.540	3.048
D	.223	.337	5.664	8.560
D1	.457-.490		11.60-12.45 typ	
D2	.277-.303 typ		7.04-7.70 typ	
D3	.244-.252 typ		6.22-6.4 typ	
E	.590	.615	14.986	15.621
E1	.302	.326	7.68	8.28
E2	.227	.251	5.77	6.37
F	.143	.153	3.632	3.886
G	1.105	1.147	28.067	29.134
H	.500	.550	12.700	13.970
L	.025	.036	.635	.914
M	.045	.055	1.143	1.550
N	.195	.205	4.953	5.207
P	.165	.185	4.191	4.699
Q	.048	.054	1.219	1.372
S	3°	6°	3°	6°
T	3°	6°	3°	6°
U	3°	6°	3°	6°
V	.094	.110	2.388	2.794
W	.014	.025	.356	.635
X	3°	5.5°	3°	5.5°
Y	.385	.410	9.779	10.414
Z	.130	.150	3.302	3.810

NOTE:

1. Dimension L, M, W apply for Solder Dip Finish

Recommended Solder Pad Layout

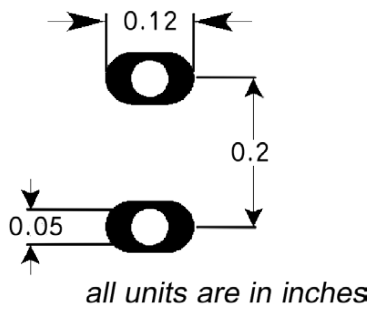

Diode Model

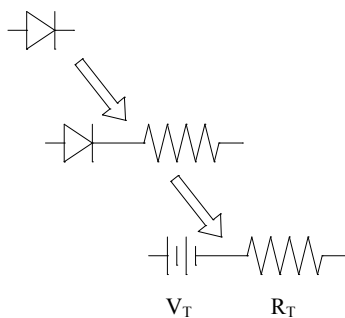

$$V_f = V_T + I_f * R_T$$

$$V_T = 0.94 + (T_J * -1.3 * 10^{-3})$$

$$R_T = 0.044 + (T_J * 4.4 * 10^{-4})$$

Note: T_J = Diode Junction Temperature In Degrees Celsius, valid from 25°C to 175°C